



better analysis counts

Elemental Analysis Advanced

Rapid sulfur measurement plus 12 elements from P to Zn.



Petra **MAX**
Elemental Analyzer for Petroleum

Petra **4294**
Sulfur Analyzer for Petroleum

ASTM D4294
ISO 8754 | IP 336

Advanced Precision

The Petra series complies with ASTM D4294 and ISO 8754 for sulfur analysis in various hydrocarbon matrices. Petra 4294™ delivers precise sulfur analysis with limits of detection (LOD) as low as 2.6 ppm. Petra MAX™ delivers a sulfur LOD as low as 5.7 ppm with rapid monitoring of critical elements like Ni, V, and Fe at sub-ppm levels.



Petra MAX Applications

- Hydrocarbons
- Water
- Catalyst Powder
- Carbon Powder

The blending of crude oils from different sources has become more commonplace within the industry to meet specifications for the classification of sweet crude oil. The introduction of new crudes brings new challenges, like higher concentrations of metals such as nickel (Ni), vanadium (V), and iron (Fe). Ni and V are known to rapidly deactivate process catalysts in the catalytic cracker (FCC) and hydrotreaters. In response, many refiners have incorporated Ni and V analysis into their routine crude assay, and pipelines have set specifications for Ni and V in their common stream sweet crude. Fe is introduced into crude oil from corrosion byproducts during transportation and can lead to pump and exchanger fouling, and off-specification coke. The data in Table 1 represents ten separate aliquots of crude oil that were analyzed for 300 seconds by Petra MAX to demonstrate the advanced precision achievable with HDXRF® technology.

Table 1: Crude Oil Analysis by Petra MAX (ppm)

Repeats	S	V	Fe	Ni
1	4,716	0.35	0.51	2.50
2	4,752	0.35	0.42	2.47
3	4,756	0.31	0.56	2.55
4	4,833	0.41	0.57	2.57
5	4,750	0.36	0.51	2.51
6	4,690	0.32	0.47	2.51
7	4,786	0.30	0.50	2.57
8	4,721	0.32	0.49	2.55
9	4,793	0.27	0.51	2.56
10	4,749	0.31	0.49	2.52
Average	4,755	0.33	0.50	2.53
Standard Deviation	41.4	0.04	0.04	0.03

Advanced Software and Data Management

Petra offers the latest software features and data management for simple, intuitive operation.

- Store up to 30 calibration curves
- Data output via Ethernet connection to LIMS or transfer over USB
- On-screen averaging allows users to quickly check performance levels across multiple measurements
- Data history stores results for 10k measurements

PRESET MEASUREMENT CONFIGURATIONS*

User: hank 18:07

Sample Name: NAPHTHA-823634

QR Code: XOS021005557

Description: Light Naphtha

Preset Details
Factory Default
Cal Curve: Standard Mineral Oil
Measurement Time: 300 sec
Matrix: Oil
Repeats: 1

Factory Default Crude Oil Gasoline
Catalyst Bunker Fuel Cylinder Oil
Naphtha

Clear Save

ADDITIONAL MATRICES AVAILABLE*

Completed

Oil

Water

Catalyst Powder

Carbon Powder

10ppm_S-2 S(10.0)

6%wt_S_in_MO S(60000.0)

25ppm_S_in_... S(25.0)

100ppm_S-2 S(100.0)

Activate Save

*Non-hydrocarbon matrices only available with Petra MAX.

Advanced Analysis with HDXRF

Petra is powered by High Definition X-ray Fluorescence (HDXRF[®]) technology: an elemental analysis technique offering significantly enhanced detection performance over traditional XRF technology. HDXRF is XOS' brand for monochromatic excitation EDXRF. This technique applies state-of-the-art monochromating and focusing optics, enabling dramatically higher signal-to-background ratio compared to traditional polychromatic X-ray Fluorescence. **Figure 1** shows the basic configuration of HDXRF and its use of focused monochromatic excitation.

Figure 1: HDXRF Technology

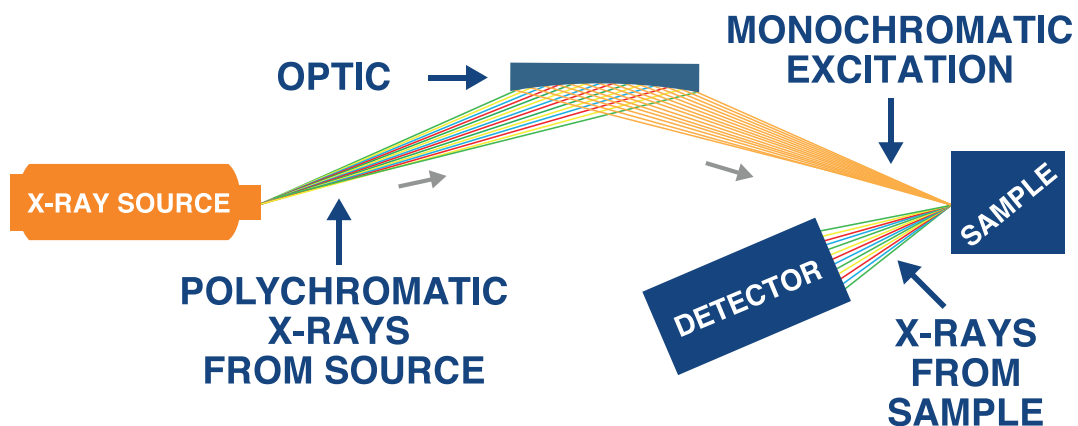

Advanced Workflow

Petra boasts an innovative autosampler design and advanced software features for a more flexible and efficient workflow.

PRESET YOUR MEASUREMENT CONFIGURATIONS

Customizable measurement configurations allow you to select the correct calibration curve, measurement time, and sample matrix for a foolproof process.

ELIMINATE DATA ERRORS

Eliminate data errors with QR-coded sample cups. The sample cup is scanned on the measurement configuration screen, and again when it reaches the measurement chamber to ensure the correct sample name and measurement parameters are paired with results, every time.

REDUCE IDLE TIME WITH CONTINUOUS SAMPLE LOAD

The 8-position sample slide offers continuous loading, allowing you to add urgent samples to the queue even during analysis.



2



4

5

How it Works

- 1 Use integrated scanner or onscreen keyboard to enter sample name
- 2 Scan sample QR-code
- 3 Select preset measurement configuration and insert sample into autosampler
- 4 QR-code is scanned in measurement chamber to retrieve sample name and measurement configuration
- 5 Measurement begins automatically. Upon completion, sample is ejected and next in queue is measured.

The Autosampler is an optional add-on feature, and can be added to an existing Petra 4294 or Petra MAX analyzer. QR/barcode scanner included with purchase. QR-coded cups are not mandatory - standard XRF cups may be used with the analyzer.

Advanced Sample Introduction

PROTECT VALUABLE COMPONENTS

Petroleum laboratories depend on reliable, robust analytical solutions for their fast-paced environment. Petra was designed to meet these needs with an innovative sample introduction system that directs accidental spills to a drip tray and away from valuable components.

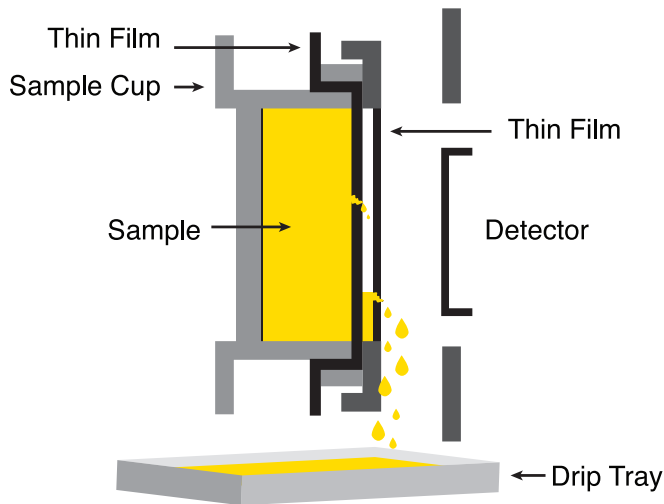

Petra Sample Chamber with Drip Tray

A sample is placed into the Petra sample chamber and when closed, it is turned on its side. This innovative design ensures that any accidental sample leaks are directed to a drip tray - to be easily removed and disposed.

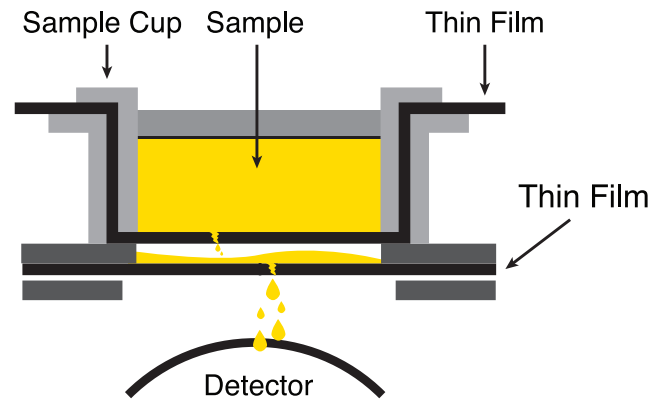

Competitor Sample Chamber

Most competitor sample chamber designs offer a thin film covering the cell window to protect the detector and X-ray tube from accidental sample leaks. If this thin film tears, the sample will leak onto the detector and X-ray tube - a very costly repair.

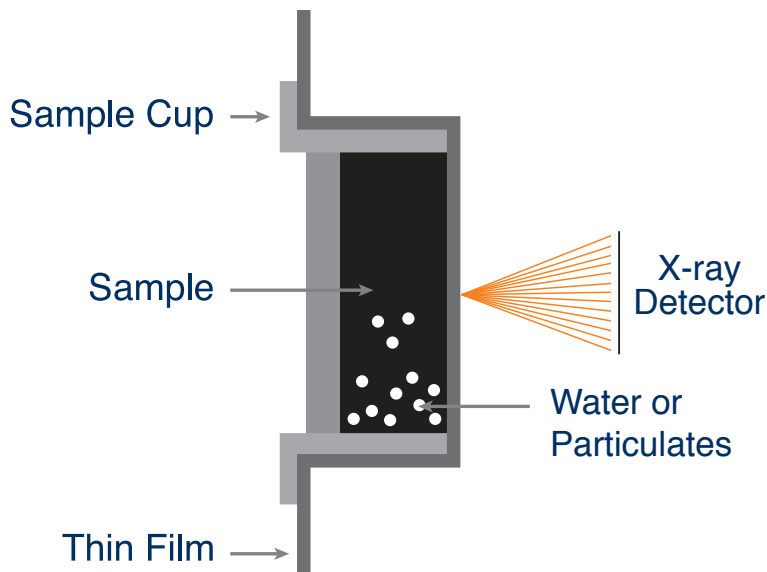

ELIMINATE CENTRIFUGE

Interfering elements like Si, Ca, Cl, Fe and water are commonly present in crude oil and will settle to the bottom of a sample over time. These interferences can absorb the X-ray signal and reduce the concentration of sulfur reported. To prevent biased results, many laboratories centrifuge the samples prior to analysis, which increases the amount of processing and time it takes to perform the measurement. Petra's sample chamber rotates the sample on its side providing a clear measurement window for more accurate results, and eliminating the need to centrifuge.

Technical Specifications

Dynamic Range, LOD & Applications							
Petra MAX	Dynamic Range	Sulfur 5.7 ppm – 10 wt%					
	Limit of Detection (ppm @ 600 s)	Sulfur 5.7 ppm					
		P	Cl	K	Ca	V	Cr
		17	3	0.7	0.4	0.1	0.09
	Mn	Fe	Co	Ni	Cu	Zn	
	0.07	0.07	0.07	0.04	0.1	0.1	
	Applications	Hydrocarbons, water, and catalysts					
Petra 4294	Dynamic Range	Sulfur 2.6 ppm – 10 wt%					
	Limit of Detection (ppm @ 600 s)	Sulfur 2.6 ppm					
	Applications	Hydrocarbons					

Petra Series Specifications	
Method Compliance	ASTM D4294, ISO 8754 & IP 336
Measurement Time	30-900 seconds
Calibration	30 calibration curves
Sample Cup Volume	7 mL
Data Output	Printout, USB, and Ethernet to PC connection
I/O Ports	Ethernet 10/100, USB
Power Supply	110-240 VAC ± 10%, 50-60 Hz (hertz)
Operating Temperature	+41°F to 104°F (5°C to 40°C)
Operating Humidity	30 – 85 %
Weight & Dimensions	<div style="display: flex; align-items: flex-start;"> <div style="flex: 1;"> <p>A Unit without Autosampler Weight: 28lbs (12.7 kg) Dimensions: 14.5 in W x 16.5 in L x 6 in H (36.8 cm W x 41.9 cm L x 15.3 cm H)</p> </div> <div style="flex: 1; text-align: center;"> </div> <div style="flex: 1;"> <p>B Unit with Autosampler Weight: 33 lbs (15 kg) Dimensions: 16.5 in W x 16.5 in L x 21 in H (41.9 cm W x 41.9 cm L x 38.9 cm H)</p> </div> <div style="flex: 1; text-align: center;"> </div> </div>