

# TD100-xr

Enabling confident, high-throughput,  
automated thermal desorption analysis

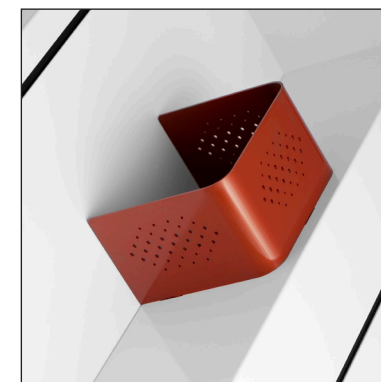
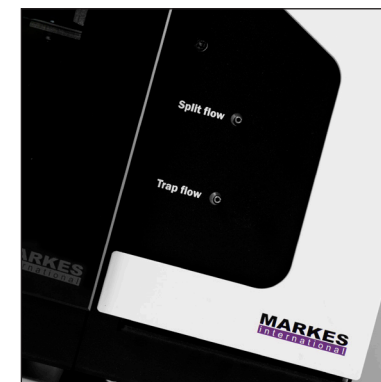

# TD100-xr<sup>TM</sup>

## Introducing the TD100-xr automated thermal desorber for GC and GC-MS – an unrivalled platform for the analysis of trace-level volatile and semi-volatile organic compounds (VOCs and SVOCs) in air and materials.

Markes International has for the last 20 years been the world leader in innovation for thermal desorption. We now present the TD100-xr, which like the other members of the 'xr' series incorporates new, powerful technical advances, making it perfect for a wide range of sample types and applications.

The TD100-xr gives you the following advantages compared to every other thermal desorber on the market:

- Extended re-collection
- Extended analyte range
- Extended reliability.

### Outstanding productivity

Automated, cryogen-free, unattended operation for up to 100 sample tubes.

### Enhanced reliability

High-precision parts result in increased robustness.

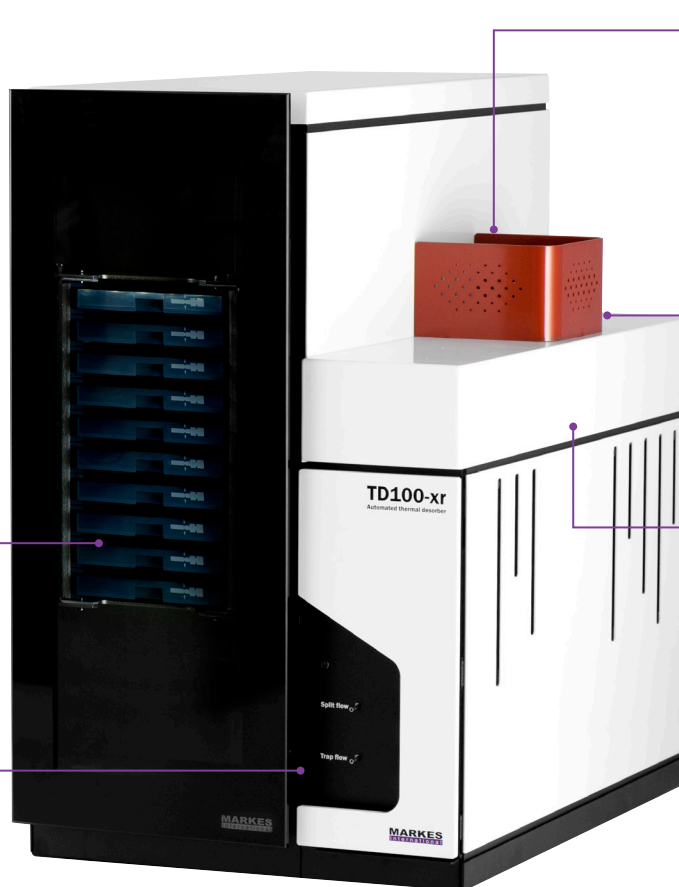

### Unbeatable application versatility

Inert sample paths and extended temperatures allow quantitative recovery of C<sub>2</sub> to C<sub>44</sub>, including reactive and thermally labile species... from percent to sub-ppt concentrations.

### Platform-neutral

The short, heated transfer line allows TD100-xr to be installed on all major makes of GC and GC-MS.

### Superior sample integrity and traceability

- Confidence in results through quantitative sample re-collection of split flows.
- Method compliance aided by leak-testing, water management and addition of internal standard.
- Enhanced traceability of samples using barcodes and RFID TubeTAGs.

# Quantitative sample re-collection of all split flows

## Powerful capabilities for repeat analysis and method validation

All models of the TD100-xr come with the unique ability to split samples during tube and/or trap desorption, and re-collect the split portions onto clean sorbent tubes. With options for manual or automated re-collection, this capability overcomes the historic 'one-shot' limitation of thermal desorption, aids method development, and allows complete analyte transfer to be validated, ensuring compliance with standard methods.

### Re-collection and repeat analysis of vapours in stack gas

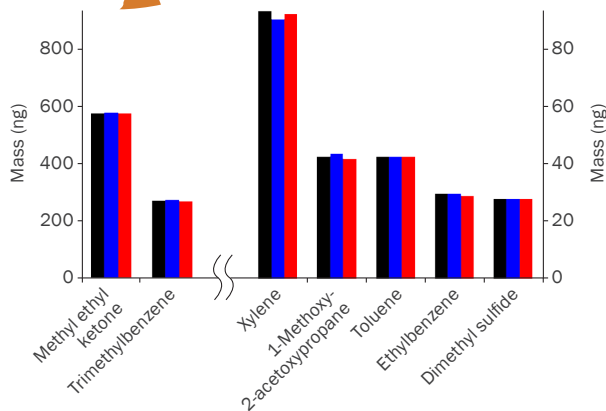
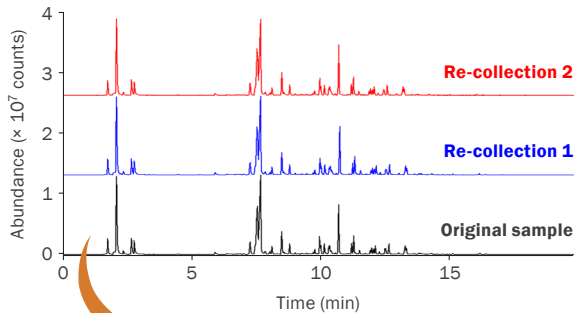

**Method-compliant, quantitative analysis of high-concentration stack gas** is confirmed by re-collecting the split sample onto a clean sorbent tube, followed by re-analysis.

## How two-stage thermal desorption works

### 1 Tube desorption and inlet split

Sample tube heated in a flow of carrier gas and analytes swept onto an electrically cooled focusing trap, typically held between ambient and  $-30^{\circ}\text{C}$ .

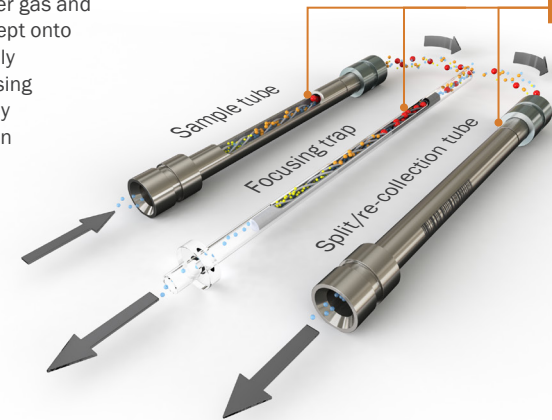

### 2 Trap desorption and outlet split

Focusing trap rapidly heated (up to  $100^{\circ}\text{C/s}$ ) in a reverse flow of carrier gas ('backflush' operation), to transfer the analytes to the GC column.

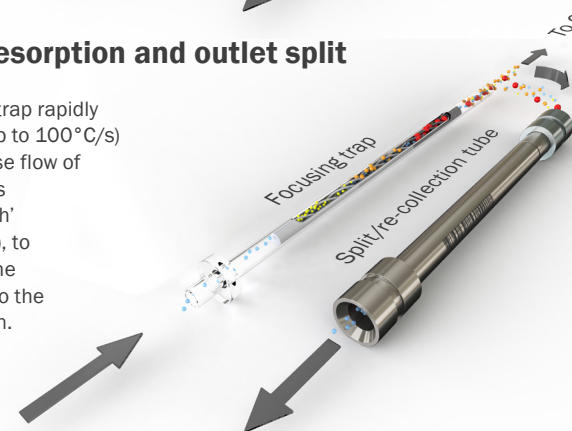

# Extended analyte scope

## From ultra-volatiles to semi-volatiles, over a wide concentration range

The uniformly inert flow path of the TD100-xr – in conjunction with tube and trap backflushing and use of optimised sorbent combinations – allows quantitative recovery and re-collection of C<sub>2</sub> to C<sub>44</sub> (including reactive and thermally labile species), from percent to sub-ppt concentrations.

### Landfill gas analysis

- |                    |                                   |                       |
|--------------------|-----------------------------------|-----------------------|
| 1 Acetaldehyde     | 7 Dichloromethane                 | 12 Trichloroethene    |
| 2 Chloroethene     | 8 Carbon disulfide                | 13 Dimethyl disulfide |
| 3 Chloroethane     | 9 1,1-Dichloroethane              | 14 Toluene            |
| 4 Pent-1-ene       | 10 <i>cis</i> -1,2-Dichloroethane | 15 Ethyl butanoate    |
| 5 Furan            | 11 Benzene                        | 16 Styrene            |
| 6 Dimethyl sulfide |                                   |                       |

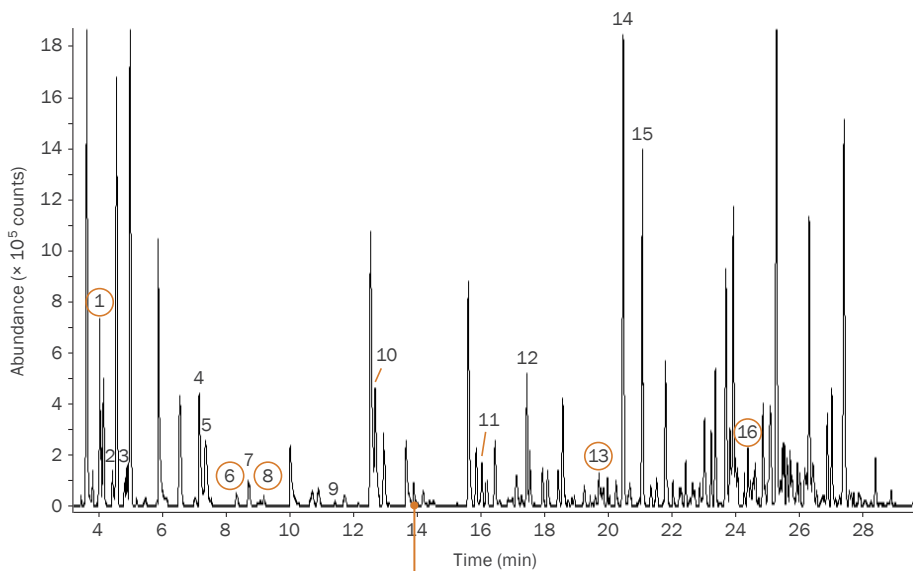

**The simultaneous detection of acetaldehyde, styrene and sulfur species** (circled) in this sample of landfill gas illustrates the ability of Markes' TD systems to analyse a wide compound range in one run.

### Polycyclic aromatic hydrocarbons in ambient air

- |                |                          |   |
|----------------|--------------------------|---|
| 1 Xylene       | 6 Phenylmaleic anhydride | 10 Pyrene                               |
| 2 Benzaldehyde | 7 Fluorene               | 11 2,5-Diphenyl- <i>p</i> -benzoquinone |
| 3 Acetophenone | 8 Phenanthrene           | 12 Decahydrobenzo[ <i>e</i> ]pyrene     |
| 4 Naphthalene  | 9 Fluoranthene           | 13 Squalene                             |
| 5 Benzoic acid |                          |   |

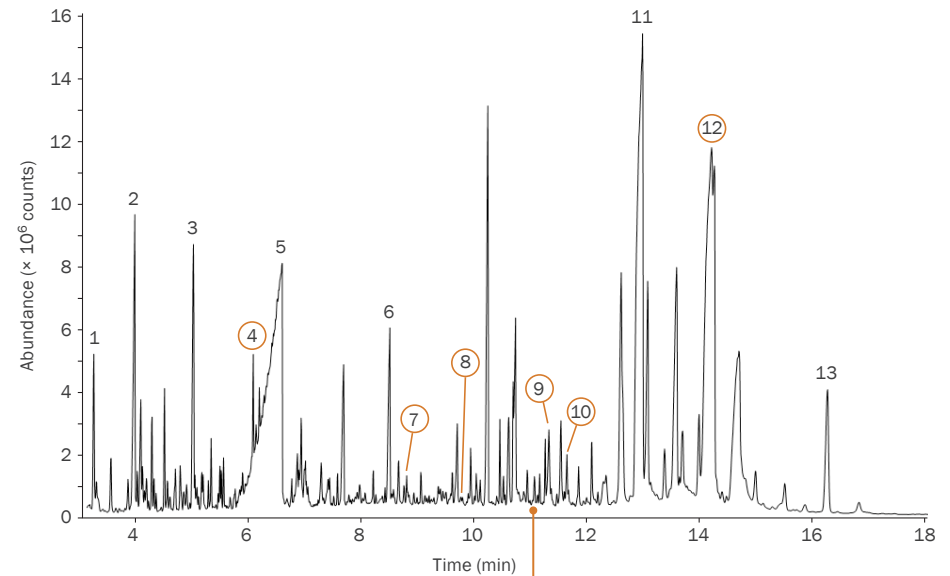

**A range of sub-ppt SVOCs** – including analytically challenging PAHs (circled) – are detected in this Chinese urban air sample, as well as typical 'air toxic' VOCs.

# Unbeatable application versatility

## Fully method-compliant analysis across a variety of application areas

The enhanced features of the TD100-xr, coupled with a suite of innovative sampling accessories, allow a wide range of applications to be run on one instrument. Across many of these areas, our involvement with technical committees and legislative agencies means that we are uniquely well-placed to advise on method compliance.

### Environmental monitoring



The TD100-xr complies with:

- US EPA Method T0-17 (ambient air)
- US EPA Method 325 (fenceline)
- Chinese Method HJ 644 (ambient air)
- New European SVOC protocols
- Method CEN/TS 13649 (stack emissions)
- Chinese Method HJ 734 (source emissions)
- and more...

### Indoor and in-vehicle air



The TD100-xr complies with:

- ISO 16000 series (indoor air)
- ASTM D6196 (indoor air)
- ISO 12219 series (automotive test)
- VDA 278 (automotive test)
- Multiple OEM standards
- and more...

### Consumer environmental health



The TD100-xr complies with:

- European Method EN TS 16516 (construction products – mandatory)
- ASTM standards (spray polyurethane foam)
- New CEN standards (combustible air fresheners)
- and more...

### Perfect for challenging applications

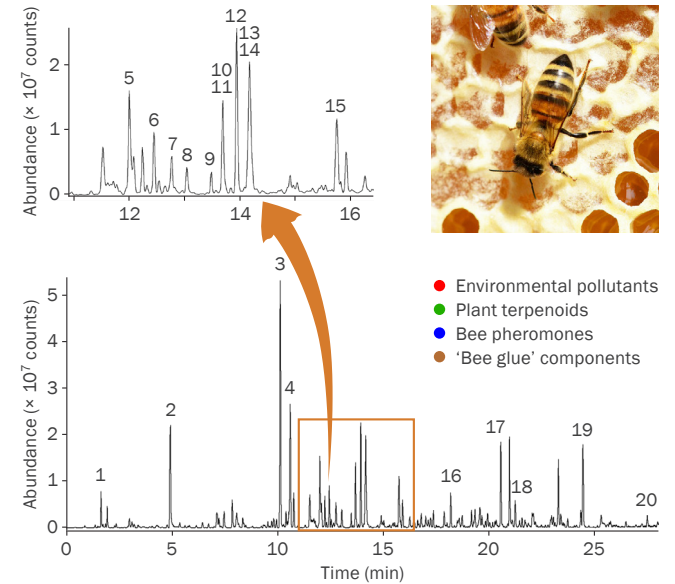

1 Acetone	8 2-Ethylhexan-1-ol	15 ● Decanal
2 Acetic acid	9 Phenyl formate	16 ● Triacetin
3 ● Styrene	10 ● Benzyl alcohol	17 ● Nerolidol
4 ● $\alpha$ -Pinene	11 ● Octan-1-ol	18 ● Guaiol
5 ● Benzaldehyde	12 ● Acetophenone	19 Benzyl
6 ● 3,3-Dimethylhexane	13 ● Methyl benzoate	20 ● 2-hydroxybenzoate
7 ● (Z)-Ocimene	14 Nonanal	20 ● Heneicosane

### Defence and homeland security



### Fragrance and odour profiling



### Food and drink



### Forensic



### Biological profiling



**Thermal desorption is not just for air monitoring...** as shown by this analysis of a complex blend of biogenic and anthropogenic volatiles in beehives.



# Outstanding productivity and reliability for TD-GC analysis

## Robust operation maximises sample throughput on the TD100-xr

**Markes' patented DiffLok caps** remain in place on tubes throughout the entire automated TD sequence, preserving sample integrity while overcoming the need to uncap and recap tubes.

**Water management:** Automatic dry-purging of water or solvent from the tube or trap improves chromatographic results.

**Efficient electrical cooling** of the focusing trap eliminates the need for cryogen, reducing operational costs and ensuring fast sample processing.

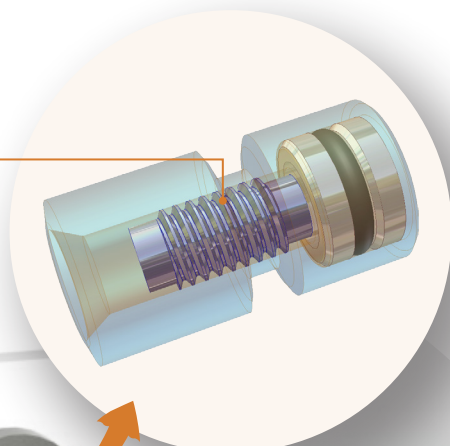

**High throughput:** 100 tubes for unattended operation over extended periods.

**Optional internal standard/dry-purge (ISDP) facility** is ideal for method validation.  
**Tube pressure-ratio testing** monitors integrity of tube packing.

**GC column connection.**

**Low consumption of expensive high-purity carrier gas** minimises running costs.

**Re-collection of all split flows** onto clean sorbent tubes allows re-analysis and method validation.

**Electronic control of split and desorb flows** (optional) increases confidence in your data and improves repeatability.

**Digital mass flow controllers** give double-split ratios of up to 125,000:1, accommodating analyte concentrations up to percent levels.

**True splitless operation** enables analysis of analysis of sub-ppt concentrations.

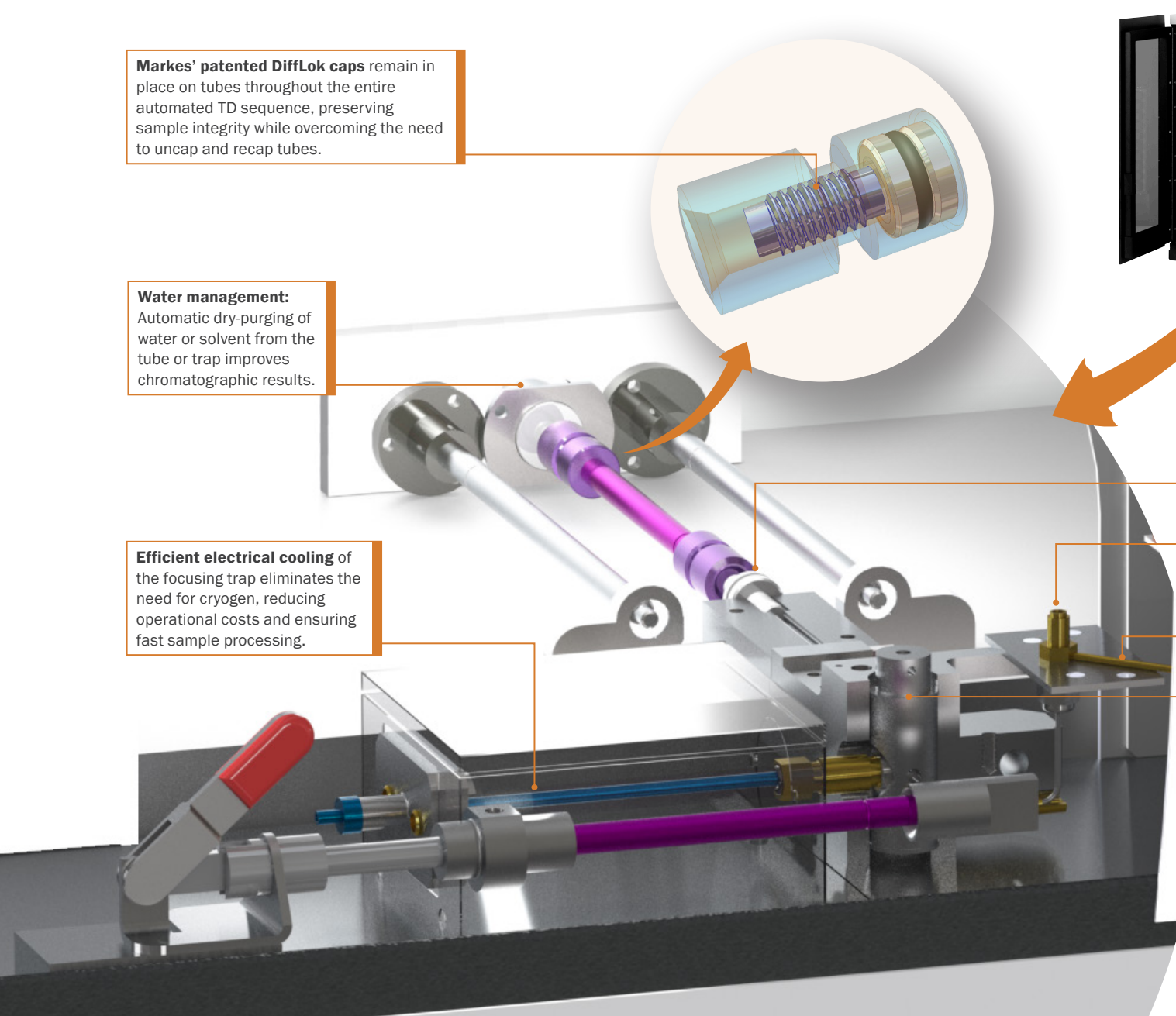

# Markes Instrument Control

Easy-to-use software for the new 'xr' series

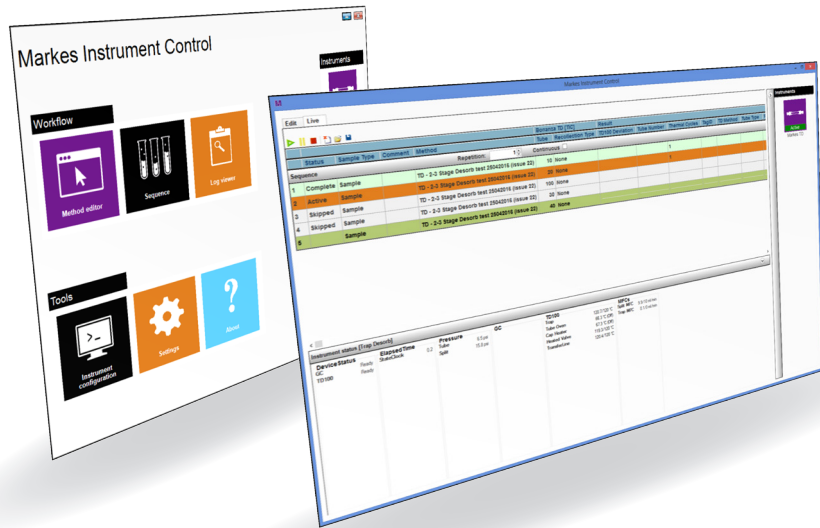

The new software used to control the TD100-xr and the other members of the 'xr' series offers the following features for enhanced laboratory productivity:

- **Editing of active sequences**, for greater flexibility and ease of use.
- **Rapid set-up of TD methods** using pre-programmed parameters for standard methods including VDA 278, US EPA TO-17 and PAH analysis.
- **Pre-loading of an internal standard** on a tube or trap, for enhanced quantitation.
- **System self-checking**, for improved diagnostics.

# Unmatched product range

A comprehensive range of sorbent tubes and sampling accessories for every TD application

**ACTI-VOC™ pump** – optimised for sorbent tube sampling.

**Micro-Chamber/Thermal Extractor™** for fast and flexible sampling of chemicals and odours released from materials and foods.

**MTS-32™** for pumped sequential sampling onto multiple tubes.

**Easy-VOC™** for simple, rapid 'grab-sampling' of air/gas.

**VOC-Mole™** for soil gas sampling.

**TubeTAG™** – RFID tags for ultimate tube traceability and quality assurance.

**Sample tubes** – Stainless steel, glass or inert-coated, individually barcoded and with single- or multi-bed sorbents for maximum application versatility.

**Brass storage caps** for ultimate sample integrity.  
**DiffLok™ caps** for tubes on autosampler.  
**Diffusion caps** for passive sampling.

# Markes International – The TD experts

## World-leading instruments and unmatched expertise in VOC and SVOC monitoring

Markes International has for 20 years been at the forefront of innovation for enhancing the measurement of trace-level VOCs and SVOCs by thermal desorption-gas chromatography. Our suite of instruments for thermal desorption sets the benchmark for quality and reliability:

### **UNITY-xr™**

Single-tube thermal desorber featuring sample re-collection of all split flows.

### **UNITY-Air Server-xr™**

Versatile on-line VOC monitoring system.

### **ULTRA-xr™**

High-throughput 100-tube autosampler for UNITY-xr.

### **CIA Advantage™**

Cryogen-free automated canister autosampler and pre-concentrator.

### **TC-20™ & TC-20 TAG™**

Cost-effective systems for off-line multi-tube conditioning and dry-purging.

### **TT24-7™**

Twin-trap instrument for near-real-time on-line monitoring.

### **Micro-Chamber/Thermal Extractor™**

Unique sampling device for emissions of VOCs and SVOCs from products and materials.

### **Markes International**

**UK:** Gwaun Elai Medi-Science Campus, Llantrisant, RCT, CF72 8XL

**T:** +44 (0)1443 230935

**US:** 11126-D Kenwood Road, Cincinnati, Ohio 45242  
2355 Gold Meadow Way, Gold River, Sacramento, California 95670

**T:** 866-483-5684 (toll-free)

**Germany:** Schleussnerstrasse 42, D-63263 Neu-Isenburg, Frankfurt

**T:** +49 (0)6102 8825569

**E:** enquiries@markes.com **W:** www.markes.com

